

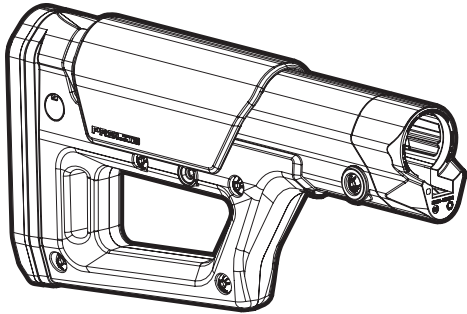

This document contains technology subject to the Export Administration Regulations (15 C.F.R. Parts 730-774). A prior authorization or license from the U.S. Department of Commerce, Bureau of Industry (and Security (BIS) is required prior to the export, re-export, release, or transfer of this document to a non-U.S. person whether in the United States or abroad.

PRS[®] LITE STOCK



MAG1159 - PRS LITE STOCK

INSTALLATION INSTRUCTIONS

⚠ WARNING: BEFORE STARTING, MAKE SURE THE WEAPON IS UNLOADED, THE CHAMBER IS EMPTY, AND THE SAFETY ENGAGED.

CARBINE RECEIVER EXTENSION

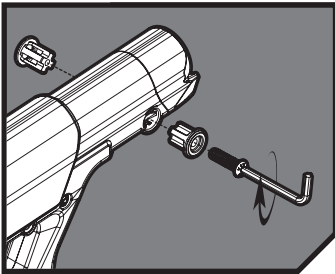

STEP 1:

Remove front QD Screw, Plug, and QD Sling Mount using a 1/8" hex wrench.

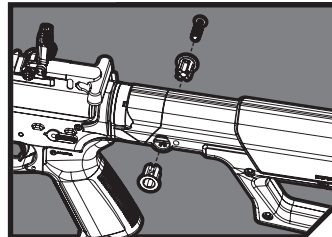

STEP 3:

Install front QD Screw, Plug, and QD Sling Mount. Torque front QD screw to 20 [in-lb] and front Body Screw until hand tight using 1/8" Hex Wrench.

Note: QD Sling Mount is reversible, can be installed on either left or right side.

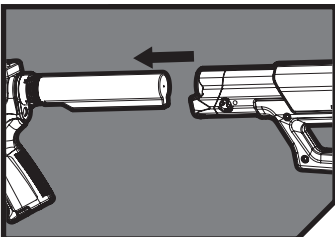

STEP 2:

Slide Stock Body over receiver extension until it is flush with the receiver end plate and castle nut.

(Designed for use with mil-spec carbine, A5, and SR25 carbine pattern receiver extensions. Not compatible with rifle-length receiver extensions.)

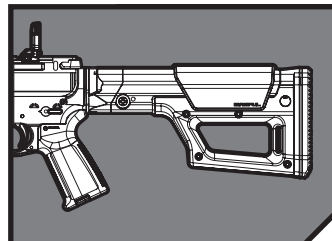

STEP 4: VERIFY INSTALL

Perform final inspection including function test per **US Army TM 9-1005-319-23&P Unit and Direct Support Maintenance Manual** to verify correct installation. If you experience any issues during installation, please contact us at www.magpul.com. Always test fire your weapon before using it in an operational environment.

ADJUSTMENTS

LENGTH OF PULL

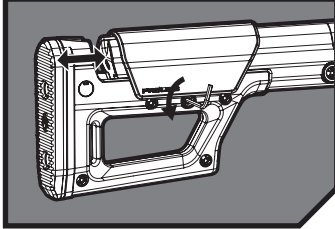

Using an *1/8" hex wrench*, loosen the *captured bolt* on the right side, under the *cheek riser*. Adjust LOP to desired position and tighten to 20 in-lbs.

COMB HEIGHT

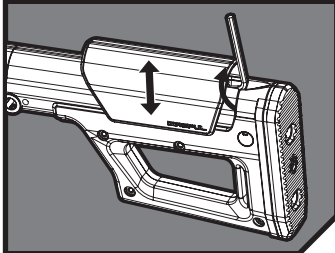

Using the *5/32" screw* at the rear of the *cheek riser*, loosen the bolt using a *5/32" hex wrench* and adjust to desired height. Re-tighten hand-tight. *Cheek Riser* adjust to a max of *3/4"* above the stock body.

BUTT-PAD HEIGHT/CANT ADJUSTMENT

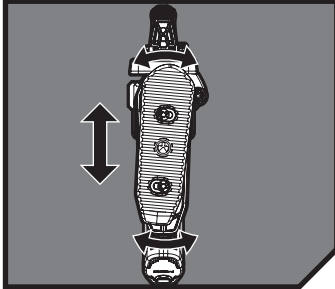

The PRS Lite *Butt-Pad* can be raised or lowered *3/4"* from center, and canted 5 degrees to the left or right. Loosen the two *Butt-Pad Retaining Screws* 1 turn, adjust to desired position, and hand tighten using a *1/8" hex wrench*.